



Macurco™ TX-12-ND
Nitrogen Dioxide Detector, Controller and Transducer
User Instructions



Important: Keep these User Instructions for reference

TABLE OF CONTENTS	
GENERAL SAFETY INFORMATION	3
Intended Use	3
List of Warnings and Cautions	3
USE INSTRUCTIONS AND LIMITATIONS	4
Use For	4
Do Not Use For	4
General Description	4
Features	5
Specifications	5
INSTALLATION AND OPERATING INSTRUCTIONS	5
Location	6
Connections	6
Installation	7
4-20 mA Output diagram	8
Rear View Image	8
Alarm Control Panel diagram	8
Multiple Device diagram	9
Alternate Alarm Panel diagram	9
DVP-120 Control Panel diagram	10
Power Up	10
Operation	10
Default - Factory Settings	10
Display setting	11
Buzzer setting	11
Alarm Relay setting	12
Alarm Relay Configuration	12
Fan Relay setting	12
Fan Relay Delay setting	13
Fan Minimum Runtime setting	13
Fan Relay Latching setting	13
Trouble Fan Setting	13
4-20mA Output setting	13
On Board Diagnostics	13
Sensor Poisons	14
MAINTENANCE	14
End-of-Warranty Signal	14
Sensor Replacement	15
Sensor Life Reset	15
Cleaning	16
Testing	16
Operation Test	16
Nitrogen Dioxide Test	18
Field Calibration Procedure	20
MACURCO GAS DETECTION PRODUCTS WARRANTY	22

GENERAL SAFETY INFORMATION

Intended Use

The Macurco TX-12-ND is a line voltage, dual relay Nitrogen Dioxide (NO₂) detector, controller and transducer. The TX-12-ND utilizes an internal switching power supply that is capable of using line voltage between 100 and 240VAC and 50-60Hz. The TX-12-ND has selectable 4-20 mA output, buzzer and digital display options. It is an electronic detection system used to measure the concentration of Nitrogen Dioxide and provide feedback and automatic exhaust fan control to help reduce Nitrogen Dioxide concentrations in parking garages, maintenance facilities or other commercial applications. The TX-12-ND is a low level meter capable of detecting from 0-20ppm of Nitrogen Dioxide. The TX-12-ND is factory calibrated and 100% tested for proper operation, but can also be calibrated in the field.

List of Warnings and Cautions within these User Instructions

WARNING

- Each person using this equipment must read and understand the information in these User Instructions before use. Use of this equipment by untrained or unqualified persons, or use that is not in accordance with these User Instructions, may adversely affect product performance and **result in sickness or death**.
- Use only for monitoring the gas which the sensor and instrument are designed to monitor. Failure to do so may result in exposures to gases not detectable and **cause sickness or death**. For proper use, see supervisor or User Instructions, or call Technical Service at 1-877-367-7891.
- This equipment may not function effectively below 0°F or above 125°F (-18°C or above 52°C). Using the detector outside of this temperature range may adversely affect product performance and **result in sickness or death**.
- This detector helps monitor for the presence and concentration level of a certain specified airborne gas. Misuse may produce an inaccurate reading, which means that higher levels of the gas being monitored may be present and could result in overexposure and **cause sickness or death**. For proper use, see supervisor or User Instructions, or call Technical Service at 1-877-367-7891.
- High voltage terminals (100/240 VAC) are located within this detector, presenting a hazard to service technicians. Only qualified technicians should open the detector case and service the internal circuits. Ensure power is removed from the detector relays prior to servicing the unit. **Failure to do so may result in sickness or death**.
- Do not disassemble unit or attempt to repair or modify any component of this instrument. This instrument contains no user serviceable parts, and substitution of components may impair product performance and **result in sickness or death**.
- Using a certified gas with a concentration other than the one listed for this detector when conducting a calibration or calibration verification test (bump test) will produce inaccurate readings. This means that higher levels of the gas being monitored may be present and could result in overexposure and **cause sickness or death**. For proper use, see supervisor or User Instructions, or call Technical Service at 1-877-367-7891.
- The following steps must be performed when conducting a calibration or calibration verification test (bump test) to ensure proper performance of the monitor. Failure to do so may adversely affect product performance and **result in sickness or death**.
 - When performing a calibration or calibration verification test (bump test) only use certified calibration gas at the required concentration level. Do not calibrate with expired calibration gas.
 - If the instrument cannot be calibrated, do not use until the reason can be determined and corrected.
 - Do not cover or obstruct display or visual alarm
 - Ensure sensor inlets are unobstructed and is free of debris

USE INSTRUCTIONS AND LIMITATIONS

WARNING

Each person using this equipment must read and understand the information in these User Instructions before use. Use of this equipment by untrained or unqualified persons, or use that is not in accordance with these User Instructions, may adversely affect product performance and **result in sickness or death**.

Use For

The TX-12-ND provides Nitrogen Dioxide detection and automatic exhaust fan control for parking garages, loading docks, truck and bus depots, firehouses, ambulance bays, warehouses and maintenance facilities. Nitrogen dioxide or NO₂ is a toxic chemical of concern in diesel exhaust. The higher average temperature of combustion of diesel engines generates more nitrogen oxides than gasoline engines. The TX-12-ND meets the requirements of the Uniform Building Code for enclosed garages and meets OSHA standards for Nitrogen Dioxide exposure. TX-12-ND can be used stand alone, with the Macurco DVP-120 Detection and Ventilation Control Panel, other fire/security panels or building automation systems.

WARNING

Use only for monitoring the gas which the sensor and instrument are designed to monitor. Failure to do so may result in exposures to gases not detectable and **cause sickness or death**. For proper use, see supervisor or User Instructions, or call Technical Service at 1-877-367-7891.

Do Not Use For

The TX-12-ND is not intended for use in hazardous locations or industrial applications such as refineries, chemical plants, etc. Do not mount the TX-12-ND where the normal ambient temperature is below 0°F or exceeds 125°F (below -18°C or above 52°C). The TX-12-ND mounts on a 4x4 electrical box supplied by the contractor. Do not install the TX-12-ND inside another box unless it has good air flow through it.

WARNING

This equipment may not function effectively below 0°F or above 125°F (-18°C or above 52°C). Using the detector outside of this temperature range may adversely affect product performance and **result in sickness or death**.

General Description

The TX-12-ND is a line voltage, dual relay Nitrogen Dioxide (ND) detector and automatic ventilation controller. The TX-12-ND uses a microcomputer controlled, electronic system to measure the concentration of Nitrogen Dioxide, actuate relays and provide a 4-20mA output. The TX-12-ND has a field replaceable, electrochemical sensor (expected life of 2+ years) and optional gas test and calibration kits. The TX-12-ND is a low level meter capable of displaying from 0-20ppm of Nitrogen Dioxide.

Features

- ETL Listed to UL 61010-1 and CAN/CSA C22.2 No 61010-1
- Low level meter capable of displaying from 0-20 ppm Nitrogen Dioxide
- The TX-12-ND meets Uniform Building Code for enclosed garages and OSHA standards for gas exposure
- Selectable fan and alarm relay activation
- 5 A SPDT fan relay controls starters of exhaust fans
- 0.5 A N.O. or N.C. alarm relay connects to warning devices or control panels
- 4-20 mA Current Loop
- TX-12-ND mounts on a standard 4x4 electrical box and becomes cover for the box
- Supervised system: any internal detector problem will cause the fan & alarm relay to activate
- Calibration kit is available. One screw allows access for calibration or gas test

Specifications

- Power: 100-240VAC (50 TO 60 HZ)
- Current: 1.0 A MAX
- Shipping Weight: 1 pound (0.45 kg)
- Size: 4 1/2 x 4 x 2 3/4 in. (11.4 X 11.4 X 7.0 cm)
- Color: Dark gray
- Connections: plugs/terminals
- Mounting box: (not included) 4x4 electric
- Fan relay: 5 A, 240 VAC, pilot duty, SPDT
- Fan relay actuation: selectable at OFF, 0.5, 0.7, 1.0, 1.2, 1.5, 1.7, 2.0, 2.2, 2.5 (default), 2.7, 3.0, 3.2, 3.5, 3.7, 4.0, 4.2, 4.5, 4.7, 5.0 ppm
- Fan Delay Settings of 0, 1, 3 (default), 5 and 10 minutes
- Fan Minimum Run Time settings are OFF (default), 3, 5, 10 or 15 minutes
- Fan relay latching or not latching (default) selectable
- Alarm relay: 0.5A 120 V, 60 VA
- Alarm relay actuation: selectable N.O. (default) or N.C.
- Alarm relay settings: OFF, 1, 2, 3, 4, 5 (default), 6, 7, 8, 9, 10, 11, 12, 13, 14, 15, 16, 17, 18, 19, 20 ppm
- Current Loop: 4-20 mA for 0-20ppm NO₂, selectable to off (default) or on
- Buzzer: 85 dBA at 10cm settable to off (default) or on
- Digital display: 3 digit LED selectable to off (default) or on.
- Operating Environment: 0°F to 125°F (-18°C to 52°C), 10 to 90% RH
- Operating altitude: Up to 5,000m (16,404ft)

INSTALLATION AND OPERATING INSTRUCTIONS

The following instructions are intended to serve as a guideline for the use of the Macurco TX-12-ND Nitrogen Dioxide Detector. It is not to be considered all-inclusive, nor is it intended to replace the policy and procedures for each facility. If you have any doubts about the applicability of the equipment to your situation, consult an industrial hygienist or call Technical Service at 1-877-367-7891.

 **WARNING**

This detector helps monitor for the presence and concentration level of a certain specified airborne gas. Misuse may produce an inaccurate reading, which means that higher levels of the gas being monitored may be present and could result in overexposure and cause sickness or death. For proper use, see supervisor or User Instructions, or call Technical Service at 1-877-367-7891.

Location

A TX-12-ND is normally mounted at breathing level, about 5 feet (1.5 meters) above the floor on a wall or column in a central area where air movement is generally good. The unit, on average, can cover about 5,000 sq. ft. (465 sq. meters). The coverage depends on air movement within the room or facility. Extra detectors may be needed near any areas where people work or where the air is stagnant. Do NOT mount the TX-12-ND where the normal ambient temperature is below below 0°F or exceeds 125°F (below -18°C or above 52°C).

 **WARNING**

High voltage terminals (120/240 VAC) are located within this detector, presenting a hazard to service technicians. Only qualified technicians should open the detector case and service the internal circuits. Ensure power is removed from the detector relays prior to servicing the unit. **Failure to do so may result in sickness or death.**

General Wiring Information

With the exception of the safety ground, all field wiring is completed via modular connectors (provided). After wiring, simply plug the modular connectors into the matching connectors on the back side of the detector.

Mains Power Connection

Mains connections should be done in accordance with National and Local Electrical Codes. Only qualified personnel should connect Mains power to any device. Macurco recommends a minimum wire size of AWG18 and the wire insulator must be rated for 140°F (60°C) service. The modular connector will accept wire from 12 to 24 AWG.

The safety ground wire should be secured to the ground screw of the metal electrical box. Tighten the screw and make sure the wire is snug. Ensure that the wire cannot be pulled out from under the screw.

The Line (L) and Neutral (N) wires should be stripped 1/4 in. (6.5 mm), insert the wire into the "L" and "N" wire positions of the modular Fan/Power connector and tighten the screw clamp. Ensure that the wire cannot be easily pulled from the connector. Plug the modular connection into the Fan/Power connection and ensure that it latches into the header properly.

Fan Relay Connection

All of the SPDT Fan relay terminals are available at the Fan/Power modular connector. Each Fan relay terminal normally open, common and normally closed (NO, COM and NC) can accommodate a wire size 12 to 24 AWG. To install the wiring for the relays, disconnect the connector from the header. Strip the insulation of each wire back approximately 1/4 in. (6.5 mm), insert the bare wire into the terminal and tighten the screw clamp. Ensure that the wire cannot easily be pulled from the connector. Plug the modular connection into the Fan/Power connection and ensure that it latches into the header properly.

Alarm Relay Connection

The external alarm connections (A and B) are available at the Alarm modular connector. There is no polarity for these connections. To install the wiring for the alarm contacts disconnect the connector from the header on the detector. Strip the insulation of each wire back approximately 1/4 in. (6.5 mm), insert the bare wire into the terminal and tighten the screw clamp. Ensure that the wire cannot easily be pulled from the connector. When the wires are connected seat the modular connector into the header ensuring that the latch engages.

4-20mA Signal Connection

The positive and negative 4-20mA signal connections (+ and -) are available at the 4-20mA modular connector, a 2-position connector. To install the wiring for the 4-20 mA contacts disconnect the connector from the header on the detector. Strip the insulation of each wire back approximately 1/4 in. (6.5 mm), insert the bare wire into the terminal and tighten the screw clamp. Ensure that the wire cannot easily be pulled from the connector. When the wires are connected seat the modular connector into the header ensuring that the latch engages.

NOTE: The 4-20mA current loop outputs may be used with the Macurco DVP-120 control panel or other systems. The 4-20mA signal connections to detectors should be size AWG18 (minimum) for short runs. Refer to the table for recommended wire gauges. Do not bundle detector 4-20mA signal connections with AC power cables to prevent electrical interference. If AC power connections must be bundled with the detector 4-20mA signal cables, the signal connections should be made with twisted pair of the appropriate gauge, with an overall foil and braid shield. All shields should be terminated at the DVP-120 end of the cable only. A ground stud is provided near the bottom left corner of the DVP-120 panel.

Installation

1. The TX-12-ND mounts on a 4" square (or 4x4) electrical box supplied by the contractor. Do not mount the TX-12-ND inside another box, unless it has good air flow through it.
2. There are two terminals for the dry alarm relay contacts, again with no polarity preference. The alarm relay can switch up to 0.5 A 120 V, or 60 VA. The alarm relay is activated if gas reaches or exceeds the alarm settings. See OPERATION section of these User Instructions for details on relay settings.
3. The alarm relay can be configured to normally open (default) (N.O.) or normally closed (N.C.) and will activate if the gas concentration exceeds alarm set point. It will deactivate once the gas concentration drops below the alarm set point. Note that the "disable" setting will cause the alarm relay not to engage at all.
4. The dry contact, SPDT fan relay has three terminals. The common (COM.), normally open (N.O.) and the normally closed (N.C.) contact. The fan relay can switch up to 5.0 A up to 240 VAC. See OPERATION section of these User Instructions for details on relay settings.
5. The Fan Relay can be configured for latching or non-latching (default) when activated (when the gas concentration exceeds fan relay set point). Once latched in, power will need to be interrupted or the "TEST" button pressed to un-latch the relay condition.
6. The Fan Relay will engage if the fan setting Nitrogen Dioxide concentration is exceeded for longer than the Fan Relay Delay time. Unless it is configured for latching, the fan relay will disengage once both of these conditions have been met:
 - Nitrogen Dioxide concentration has dropped below fan setting
 - Fan Relay Run time has been exceededNote that the "disable" fan setting will cause the fan relay to not engage. The fan relay will engage in trouble fault condition (if the Trouble Fan Setting Option is set to "ON") and will disengage once trouble fault condition is cleared.
7. The Current Loop is 4 mA in clean air and 20 mA for 20 ppm Nitrogen Dioxide

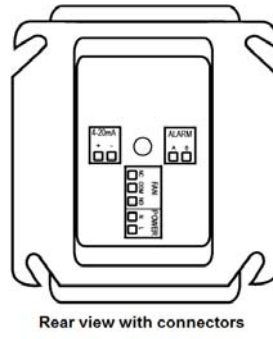
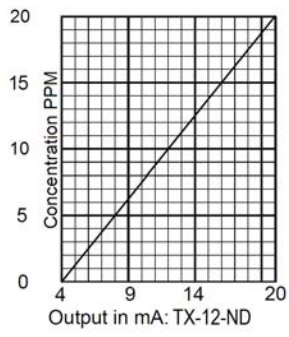

Rear view with connectors

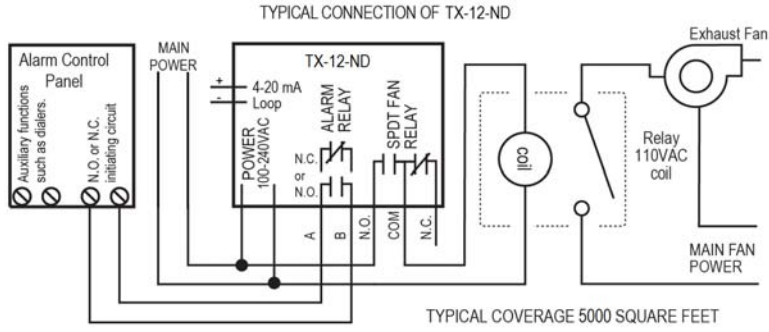

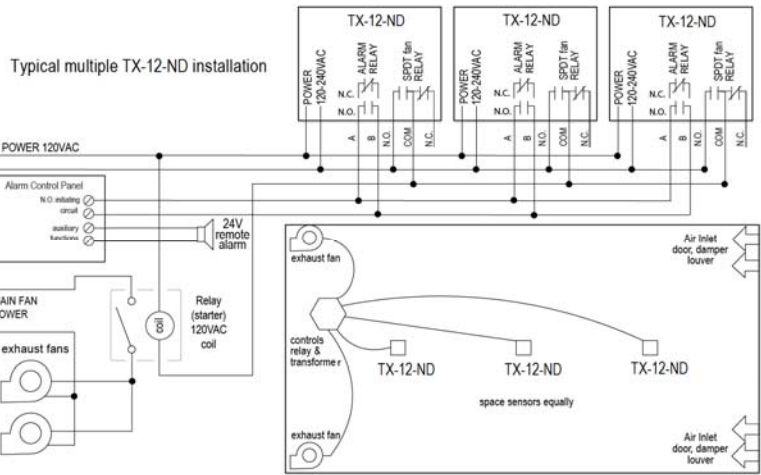

Alternate Connection to Alarm Control Panel

1. In this configuration the Fan or primary relay is used as a low level alarm relay. The Alarm or secondary relay is used as a supervisory relay when used in the normally closed option.
2. The TX-12-ND monitors all critical functions of the unit through software diagnostics that continuously test and verify unit operations. If a problem is found, the unit will switch to a fail-safe/error mode or trouble condition.
3. In this error mode the Fan and Alarm relays will be activated indicating a trouble condition at the panel and the TX-12-ND display will flash the error.

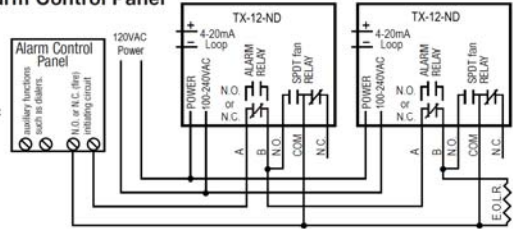

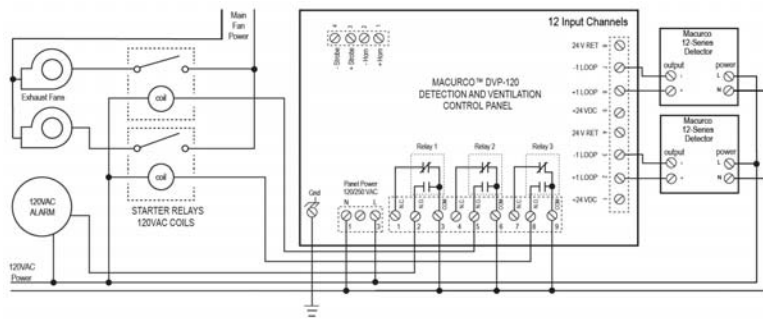

Typical connection to the Macurco DVP-120 Detection and Ventilation Control Panel

Power Up

The TX-12-ND steps through an internal self-test cycle for the first 1 minute that it is powered. The unit will execute the test cycle any time power is dropped and reapplied (i.e. power failure). During the self-test cycle the unit will display the Firmware Version number and the gas type, then count down from 60 to 0 (if the display option is "on") and finally go into normal operation. The alarm relay will be activated for 10 seconds and the fan relay for 60 seconds during the power-up cycle unless the "Power Up Test" (PUT) option is OFF. The indicator light (LED) will flash green during the self-test cycle. At the end of the 1 minute cycle, the unit will take its first sample of the air and the indicator light will turn solid green.

Operation

1. With the display function turned "On", the TX-12-ND will show the current concentration of NO₂ ppm or "0.0" (zero) in clean air. When the NO₂ concentration reaches the Fan Relay setting (1.0ppm, for example) the display will flash back and forth between "FAn" and "1.0". With the display function turned "Off", the display does not show the gas concentration, but will show "FAn" as long as the fan relay is activated.
2. With the display function turned "On" and the NO₂ concentration reaching the Alarm Relay setting, (5.0ppm, for example) the display will flash back and forth between "ALr" and "5.0". The buzzer will sound indicating "Alarm" if the buzzer is turned "On". With the display function turned off the display does not show the NO₂ concentration, but will show "ALr" when the Alarm relay is activated.
3. With the 4-20 mA function turned "On" and the NO₂ concentration climbing the 4-20 mA signal will ramp up corresponding to the concentration (0-20 ppm).

Default Configuration – Factory Settings

- The default **Power Up Test** setting is **On**
- The default **Display** setting is **Off**
- The default **Buzzer** setting is **Off**
- The default **Alarm Relay Setting** is activation at **5.0 ppm**
- The default **Alarm Relay Configuration** is **Normally Open**
- The default **Fan Relay Setting** is activation at **2.5 ppm**
- The default **Fan Relay Delay** setting is **3 minutes**
- The default **Fan Relay Runtime** setting is **OFF**
- The default **Fan Relay Latching** condition is **OFF**
- The default **Trouble Fan Setting** condition is **OFF**
- The default **4-20mA Output** setting is **OFF**

To change settings, remove the Phillips screw on the front of the TX-12-ND. Pull off the front cover of the unit.

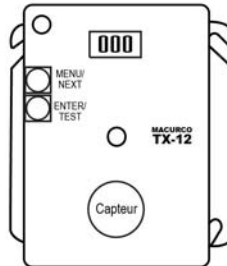

Selecting Default Configuration – “dEF”

To select the Default Configuration, in normal mode, push the *Next* button to get to “Con” or the Configuration menu. Then push the *Enter* button to enter the Con menu. The **first** selection is the “dEF” or Default setting. Push *Enter*. If it is already in Default configuration, there will be no action. If it is not already in Default configuration, “nO” will be displayed. Push *Next* to change it to “YES” (flashing) then push *Enter* to confirm the change (solid) and push *Enter* again to return to “dEF” in the con menu. Push *Next* until “End” is displayed then push *Enter* to get back to normal operation.

Selecting Power Up Test Option – “PUt”

To select the **Power Up Test Configuration**, in normal mode, push the *Next* button to get to “Con” or the Configuration menu. Then push the *Enter* button to enter the Con menu. Then push the *Next* button to get to the **second selection** “PUt” or **Power Up Test** setting. Push *Enter*. If the test is “On” push *Next* to turn it “OFF” (flashing) then push *Enter* to confirm the change (solid) and push *Enter* again to return to “PUt” in the Con menu. Push *Next* until “End” is displayed then push *Enter* to get back to normal operation.

Selecting Display Option – “dSP”

To select the **Display Configuration**, in normal mode, push the *Next* button to get to “Con” or the Configuration menu. Then push the *Enter* button to enter the Con menu. Then push the *Next* button to get to the **third selection** “dSP” or Display setting. Push *Enter*. If the display is “On” push *Next* to turn it “OFF” (flashing) then push *Enter* to confirm the change (solid) and push *Enter* again to return to “dSP” in the Con menu. Push *Next* until “End” is displayed then push *Enter* to get back to normal operation.

Selecting Buzzer Option – “bUZ”

To select the **Buzzer Configuration**, in normal mode, push the *Next* button to get to “Con” or the Configuration menu. Then push the *Enter* button to enter the Con menu. **The fourth selection** is the “bUZ” or Buzzer setting. Push *Next* three times to get to “bUZ” then *Enter*. If the display is “On” push *Next* to turn it “OFF” (flashing) then push *Enter* to confirm the change (solid) and push *Enter* again to return to “bUZ” in the Con menu. Push *Next* until “End” is displayed then push *Enter* to get back to normal operation.

Selecting Alarm Relay Setting – “ArS”

To select the **Alarm Relay Setting**, in normal mode, push the *Next* button to get to “Con” or the Configuration menu. Then push the *Enter* button to enter the Con menu. **The fifth selection** is the “ArS” or Alarm Relay Setting. Push *Next* four times to get to “ArS” then *Enter*. If the display is “OFF” (disabled) push *Next* to change it to 1, 2, 3, 4, 5, 6, 7, 8, 9, 10, 11, 12, 13, 14, 15, 16, 17, 18, 19 or 20ppm (flashing) then push *Enter* to confirm the change (solid) and push *Enter* again to return to “ArS” in the Con menu. Push *Next* until “End” is displayed then push *Enter* to get back to normal operation.

Selecting Alarm Relay Configuration – “Arc”

To select the **Alarm Relay Configuration**, in normal mode, push the *Next* button to get to “Con” or the Configuration menu. Then push the *Enter* button to enter the Con menu. **The sixth selection** is the “Arc” or Alarm Relay Configuration. Push *Next* five times to get to “Arc” then *Enter*. If the relay is “nO” (normally open) push *Next* to turn it to “nC” (flashing) then push *Enter* to confirm the change (solid) and push *Enter* again to return to “Arc” in the Con menu. Push *Next* until “End” is displayed then push *Enter* to get back to normal operation.

Selecting Fan Relay Settings – “FrS”

To select the **Fan Relay setting**, in normal mode, push the *Next* button to get to “Con” or the Configuration menu. Then push the *Enter* button to enter the Con menu. **The seventh selection** is the “FrS” or Fan Relay setting. Push *Next* six times to get to “FrS” then *Enter*. If the fan relay is “OFF” (disabled) push *Next* to change it to 0.5, 0.7, 1.0, 1.2, 1.5, 1.7, 2.0, 2.2, 2.5, 2.7, 3.0, 3.2, 3.5, 3.7, 4.0, 4.2, 4.5, 4.7, 5.0 ppm (flashing) then push *Enter* to confirm the change (solid) and push *Enter* again to return to “run” in the Con menu. Push *Next* until “End” is displayed then push *Enter* to get back to normal operation.

Selecting Fan Relay Delay – “FrD”

To select the **Fan Relay Delay setting**, in normal mode, push the *Next* button to get to “Con” or the Configuration menu. Then push the *Enter* button to enter the Con menu. **The eighth selection** is the “FrD” or Fan Relay Delay. Push *Next* seven times to get to “FrD” then

Enter. If the delay is "OFF" (disabled) push *Next* to change it to 1, 3, 5, or 10 minutes (flashing) then push *Enter* to confirm the change (solid) and push *Enter* again to return to "FrD" in the Con menu. Push *Next* until "End" is displayed then push *Enter* to get back to normal operation.

Selecting Fan Relay Run Time – "Frr"

To select the Fan Minimum Runtime setting, in normal mode, push the *Next* button to get to "Con" or the Configuration menu. Then push the *Enter* button to enter the Con menu. The **ninth selection** is the "Frr" or Fan Minimum Run Time. Push *Next* eight times to get to "Frr" then *Enter*. If the runtime is "OFF" (disabled) push *Next* to change it to 3, 5, 10 or 15 minutes (flashing) then push *Enter* to confirm the change (solid) and push *Enter* again to return to "run" in the Con menu. Push *Next* until "End" is displayed then push *Enter* to get back to normal operation.

Selecting Fan Relay Latching Option – "FrL"

To select the **Fan Relay Latching Option**, in normal mode, push the *Next* button to get to "Con" or the Configuration menu. Then push the *Enter* button to enter the Con menu. The **tenth selection** is the "FrL" or Fan Relay Latching Option. Push *Next* nine times to get to "FrL" then *Enter*. If latching is "OFF" push *Next* to turn it to "ON" (flashing) then push *Enter* to confirm the change (solid) and push *Enter* again to return to "FrL" in the Con menu. Push *Next* until "End" is displayed then push *Enter* to get back to normal operation.

Selecting Trouble Fan Setting Option – "IFS"

To select the **Trouble Fan Setting Option**, in normal mode, push the *Next* button to get to "Con" or the Configuration menu. Then push the *Enter* button to enter the Con menu. The **eleventh selection** is the "IFS" or Trouble Fan Setting Option. Push *Next* ten times to get to "IFS" then *Enter*. If Trouble Fan Setting is "OFF" push *Next* to turn it to "ON" (flashing) then push *Enter* to confirm the change (solid) and push *Enter* again to return to "IFS" in the Con menu. Push *Next* until "End" is displayed then push *Enter* to get back to normal operation.

Selecting 4-20mA Output Option – "420"

To select the **4-20mA Output Option**, in normal mode, push the *Next* button to get to "Con" or the Configuration menu. Then push the *Enter* button to enter the Con menu. The **twelfth selection** is the "420" or 4-20mA Output Option. Push *Next* eleven times to get to "420" then *Enter*. If the 4-20mA is "On" push *Next* to turn it to "OFF" (flashing) then push *Enter* to confirm the change (solid) and push *Enter* again to return to "420" in the Con menu. Push *Next* until "End" is displayed then push *Enter* to get back to normal operation.

Onboard Diagnostics

The TX-12-ND monitors all critical functions of the unit through software diagnostics that continuously test and verify unit operations. If a problem is found, the unit will switch to a fail-safe/error mode or trouble condition. In this error mode, the Alarm relay will be activated, the 4-20 mA current loop will go to 24 mA, the unit will display the error code, the green status indicator LED light will flash and the buzzer will chirp intermittently. The Fan relay will also engage if the Trouble Fan Setting Option is set to "ON". This is a safety precaution. To clear this mode, simply turn off power to the unit for a few seconds, or push the TEST switch (inside the unit). This will cause the unit to restart the 1 minute self-test cycle.

The 4-20 mA signal can be used for troubleshooting:

- 0 mA is most likely a connection problem
- 4-20 mA is normal gas reading range (0-20 ppm)
- 24 mA indicates a Trouble condition

Error Codes

- 101 Sensor missing
- 102 Temperature compensation failure
- 104 EEPROM bad checksum
- 110 Bad EEPROM
- 120 Bad calibration
- 140 Factory calibration failure
- 180 Read ADC failure
- 1100 Under range
- 1200 Sensor warranty expired

NOTE: For trouble codes over 080 the display will alternate between L_1 and t00 for 1100 and between L_2 and t00 for 1200.

If the error mode repeats frequently, check for continuous power and proper voltage. If power is not the problem and a unit has repeating error conditions, it may need to be returned to Macurco for service, per these User Instructions.

If the error mode indicates "Sensor warranty expired" see the **Sensor Replacement** section of these User Instructions.

Sensor Poisons

The gas sensor in the detector is designed with extreme sensitivity to the environment. As a result, the sensing function may be deteriorated if it is exposed to a direct spray from aerosols such as paints, silicone vapors, etc., or to a high density of corrosive gases (such as hydrogen sulfide, sulfur dioxide) for an extended period of time.

MAINTENANCE

The TX-12-ND requires periodic maintenance. The unit uses an electrochemical sensor with a 2-3 year life expectancy that can be tested, calibrated and replaced in the field. The TX-12-ND replacement sensor is available through your local representative or from Macurco. The detector's performance should be tested regularly by using gas as detailed in the Testing and Field Calibration sections. All other maintenance and repair of products manufactured by Macurco are to be performed at the appropriate Macurco manufacturing facility. Macurco does not sanction any third-party repair facilities.

End-of-Warranty Signal

Two years after the TX-12-ND is installed the sensor end-of-warranty signal will be activated indicating that the TX-12-ND sensor has reached the end of its warranty period. The end-of-warranty signal will cause an error code 1200 "Sensor warranty expired". See Error Codes section. In addition to the end-of-warranty signal the sensor itself has a tamper proof warranty expiration sticker dated 2 years from the unit manufacture date. See the Macurco Fixed Gas Detection Products Limited Warranty section.

The end-of-warranty signal can be silenced for 48 hours by pressing the "ENTER/TEST" button or by temporarily dropping power to the unit. The end-of-warranty signal provides the user an opportunity to test and/or calibrate the sensor assuring that it is still performing within acceptable parameters though the sensor is nearing the end of its 2-3 year expected life. The silence function will continue to be available for 29 days after the TX-12-ND initiates the initial end-of-warranty signal. After this 29 day period the TX-12-ND can no longer be silenced and the sensor must be replaced or the sensor life reset.

Sensor Replacement

1. Remove power to the unit
2. Remove the Philips screw on the front of the TX-12-ND. Pull the front cover of the unit off.
3. Remove the sensor by pulling it gently from the three pronged socket.
4. Remove the Shorting Spring from the new sensor and insert the new sensor into the socket.
5. Power up the unit. The TX-12-ND steps through an internal self-test cycle for the first 1 minute that it is powered. During the self-test cycle the unit will display the Firmware Version number, then count down from 60 to 0 and finally go into normal operation. The indicator light (LED) will flash green during the self-test cycle. At the end of the 1 minute cycle, the unit will take its first sample of the air and the indicator light will turn solid green.
6. Let the new sensor stabilize for at least 5 minutes then refer to the **FIELD CALIBRATION PROCEDURE** section to zero and calibrate the unit.
7. After the successful calibration is complete, reset the sensor life.

Sensor Life Reset

1. Remove the Philips screw on the front of the TX-12-ND. Pull the front cover of the unit off.
2. To reset the sensor life (**rSt**), from normal or warm-up mode, press the **Next** button four times to get to **SEn** or **Sensor Mode**.
3. Then press the **Enter** button to get to **rSt** - Reset Sensor Mode.
4. Press the **Enter** button again to see the sensor reset status. If the sensor life has already been reset, done **don** will be displayed. If it has not already been reset, **no** will be displayed. Push **Next** to change it to **YES** (flashing) then push **Enter** to confirm the change (solid) and push **Enter** again to return to **rSt** in the **SEn** menu. Push **Next** until **End** is displayed then push **Enter** to get back to normal operation.

NOTE: If the sensor is reset and not replaced it is necessary to test and/or calibrate the sensor to assure that it is still performing within acceptable specifications though the sensor is nearing the end of its 2-3 year expected life. There will be no other indication of sensor performance.

WARNING

Do not disassemble unit or attempt to repair or modify any component of this instrument. This instrument contains no user serviceable parts, and substitution of components may impair intrinsic safety, which may adversely affect product performance and **result in sickness or death.**

CAUTION

Avoid the use of harsh cleaning materials, abrasives and other organic solvents. Such materials may permanently scratch the surfaces and damage the display window, labels, sensor or instrument housing.

Cleaning

Cleaning of the external surfaces is best carried out using a damp cloth with a mild detergent or soap. Use a vacuum cleaner with soft brush to remove dust or contamination under the cover. Do not blow out the sensor with compressed air.

TESTING

WARNING

Using a certified gas with a concentration other than the one listed for this detector when conducting a calibration or calibration verification test (bump test) will produce inaccurate readings. This means that higher levels of the gas being monitored may be present and could result in overexposure and **cause sickness or death**. For proper use, see supervisor or User Instructions, or call Technical Service at 1-877-367-7891

General

All TX-12-ND units are factory calibrated and 100% tested for proper operation. During normal operation the green status indicator LED light will be on steady, the fan & alarm relay will be in standby mode and the 4-20 mA output will be at 4mA (in clean air). The unit also performs a regular automatic self-test during normal operation. If the unit detects an improper voltage or inoperable component, it will default into Error mode. In this error mode, the Alarm relay will be activated, the 4-20 mA current loop will go to 24 mA, the unit will display the error code, the green status indicator LED light will flash and the buzzer will chirp intermittently. The Fan relay will also engage if the Trouble Fan Setting Option is set to "ON".

Operation Test

Check that the green TX-12-ND status indicator LED light is illuminated continuously. If not, do not proceed with the tests. If the unit is in error mode contact your local representative or Macurco technical service representative for information on resolving the problem.

1. Remove the single screw in the middle of the front cover of the TX-12-ND.
2. Remove the front cover.
3. Observe the LED light on the front of the TX-12-ND.
4. If the light is solid green proceed to step 6.
5. If the green status indicator LED light is off or flashing, refer to the General section above.
6. Locate the switch labeled ENTER/TEST on the left side of the printed circuit board. Push the Test switch once.
7. The TX-12-ND will step through a cycle test:
 - a) The display progresses through the **brt** (buzzer test), **Art** (alarm relay test), **Frnt** (fan relay test) then **42t** (4-20 mA output test).
 - b) During the first 3 seconds of the test cycle, the Buzzer will sound
 - c) During the next 5 seconds of the test cycle, the Alarm relay will be closed, so any devices connected to that relay will be tested.
 - d) The Fan relay will be activated for the next 1 minute of the test, so if the fan circuits are wired in the normal manner, the fan should run.

- e) The 4-20mA output will then ramp up from 4 to 16 mA over the next 130 seconds of the test, so if the circuit is wired in the normal manner, the control panel or building automation system should respond.
- f) At the end of the test cycle, the light will turn green and be on steady (Normal Operation), the Fan & Alarm relay will be in standby mode and the 4-20 mA output will return to 4 mA (in clean air).

8. When testing is completed reassemble the unit or units.

Manual Operation Test

This option gives the user the opportunity to manually initiate an individual test for each relay, the analog output and the sensor response to gas. From normal operation mode press the **Next** button 2 times to get to the Test Mode (tSt). Press the **Enter** button once to get into the Test Menu. Press the **Next** button to scroll through the five test options and press **Enter** to initiate the selected test. Note that if the relay or 4–20 mA output has been disabled, the test selection will not be displayed in the test menu.

brt – Buzzer Test, 3 seconds

Art - Alarm Relay Test, 10 seconds

Frt - Fan Relay Test, 60 seconds

42t - 420 loop test, 25 seconds

gtS - Gas Test, 3 minutes (no output to the panel during the gas test)

The display will flash during the test, or in the case of the gas test, the gas level will alternate with gtS. Once the test is complete, the display will return to steady display. To exit the test menu, press the **Next** button until "End" is displayed, then press **Enter** to return to normal mode.

Nitrogen Dioxide Gas Test



The following steps must be performed when conducting a calibration or calibration verification test (bump test) to ensure proper performance of the monitor. Failure to do so may adversely affect product performance and result in sickness or death.

- When performing a calibration or calibration verification test (bump test) only use certified calibration gas at the required concentration level. Do not calibrate with expired calibration gas.
- If the instrument cannot be calibrated, do not use until the reason can be determined and corrected.
- Do not cover or obstruct display or visual alarm cover.
- Ensure sensor inlets are unobstructed and is free of debris

General

The TX-12-ND can be bump-tested or calibrated with the ND-FCK with Nitrogen Dioxide gas, regulator and test hood, available through your local representative or from Macurco.

Contents of the FCK

- ND-FCK: (1) Gas Cylinder, 5 ppm Nitrogen Dioxide gas in air
- Gas regulator with about two feet of plastic tubing
- Gas test hood

FCK Information

Several detectors can be calibrated with one FCK. The only limitation is the amount of gas in the cylinder and the flow of the regulator. The 34 liter cylinder for example with a 0.2LPM regulator has approximately 170 minutes of continuous calibration run time. Replacement cylinders are available. The gas cylinder should be replaced when the pressure gauge on the regulator shows 25-psi or less.

Note: For optimum test results it is suggested that the unit be in clean air (green light on) and be in a low ambient air flow

Gas Testing

Testing the Fan Relay –

1. Remove the Phillips screw on the front of the TX-12-ND. Remove the front cover.
2. Open the FCK. Connect the 5 ppm gas cylinder to the regulator.
3. Check the pressure gauge on the regulator. If you have 25-psi or less you will need to replace the gas canister.
4. Assemble regulator, hose and test hood and place the Test Hood over the gas sensor.

Note: The time to activate the Fan relay depends on the delay setting.

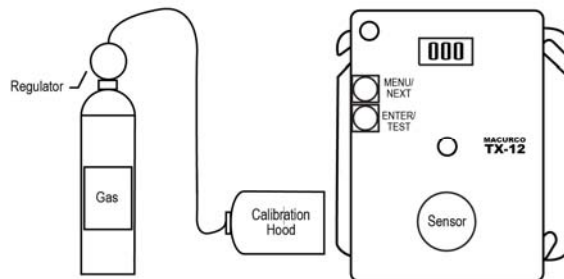

5. Turn on the regulator to start the gas flow and wait with the gas applied continuously.
6. With the display function turned "On", the TX-12-ND will show the current concentration of gas or "0.0" (zero) in clean air. When the gas concentration reaches the Fan Relay setting (1.0 ppm, for example) the display will flash back and forth between "FAn" and "1". With the display function turned "Off", the display does not show the gas concentration, but will show "FAn" as long as the fan relay is activated.

Note: If the Fan relay does not close within 2 minutes, there are four possibilities:

- a. Gas cylinder is empty, check the pressure gauge. Replace the gas cylinder if 25psi or less.
- b. Unit needs to be re-calibrated (go through recalibration and re-test).
- c. Detector is in need of servicing (return unit to factory for servicing).
- d. Detector has fan relay set to disable (OFF). Set fan relay to 3 ppm and repeat the test.
- e. Detector has fan relay delay set to 3 minutes. Set fan relay to 0 minutes and repeat the test.
- f. Remove the gas from the sensor. Proceed to Test the Alarm relay or replace the top cover. Fan relay test is complete.

Testing the Alarm Relay

Note: The gas concentration to activate the Alarm relay depends on the setting.

1. Connect the 5 ppm cylinder of Nitrogen Dioxide to the regulator.
2. Check the pressure gauge. If there is 25psi or less the cylinder should be replaced.
3. Place the test hood over the gas sensor. Turn on the regulator to start the gas flow.
4. The Fan relay should activate according to the settings.
5. With the display function turned "On" and the gas concentration reaching the Alarm Relay setting, (5.0 ppm, for example) the display will flash back and forth between "ALr" and "5.0". The buzzer will sound indicating "Alarm" if the buzzer is turned "On".
With the display function turned off the display does not show the gas concentration, but will show "ALr" when the Alarm relay is activated.

Note: If the Alarm relay fails to operate within 2 minutes, there are four possibilities:

- a. Gas cylinder is empty, check the pressure gauge. Replace the gas cylinder if 25-psi or less.
 - b. Unit needs to be re-calibrated (go through recalibration and re-test).
 - c. Detector is in need of servicing (return unit to factory for servicing).
 - d. Detector has Alarm relay set to disable (OFF). Set Alarm relay to 5 ppm and repeat the test.
6. Remove the gas from the sensor after Test. Proceed to Test the 4-20mA output or replace the top cover. Alarm relay test is complete.

Testing the 4-20mA current loop

1. Connect the 5 ppm cylinder of Nitrogen Dioxide to the regulator.
2. Check the pressure gauge. If there is 25-psi or less the cylinder should be replaced.
3. Place the test hood from the regulator over the gas sensor. Turn on the regulator to start the gas flow.
4. The Fan relay should activate according to the settings.
5. The Alarm relay should activate according to the settings.
6. The 4-20 mA output should ramp up from 4mA in clean air to 8 mA at 5 ppm. See 4-20 mA diagram on page 6.

Note: If the 4-20mA output does not ramp up within 2 minutes, there are four possibilities:

- a. Gas cylinder is empty, check the pressure gauge. Replace the gas cylinder if 25-psi or less.
 - b. Unit needs to be re-calibrated (go through recalibration and re-test).
 - c. Detector is in need of servicing (return unit to factory for servicing).
 - d. Detector has 4-20 mA option set to "OFF". Set 4-20mA option to "On" and repeat the test.
7. Remove the gas from the sensor. Re-assemble the TX-12-ND (make sure the LED is aligned with the front case hole). 4-20 current loop test is complete.

FIELD CALIBRATION PROCEDURE

Note: For optimum calibration results the unit should be in clean air and be in a low ambient air flow.

Zero the Sensor

1. Ensure that the ambient air has less than 0.1 ppm NO₂ before proceeding with Zeroing the sensor. Remove the Philips screw on the front of the TX-12-ND. Pull the front cover of the unit off.
2. To select Calibration Zero Mode (**000**), from normal mode, press the **Next** button three times to get to **CAL** or Calibration Mode.
3. Then press the **Enter** button to get to "000" - Calibration Zero Mode.
4. Press the **Enter** button and the display will read **0.0** alternating with **000** (blinking) indicating zero calibration in progress (max 165 sec).
5. If the process is successful, the display will read **0.0** alternating with **PAS** (blinking) Zero Calibration complete.
6. If the process was not successful the display will read **_1** alternating with **FAL** (**Fail**) (blinking) Zero Failed. If this occurs, repeat steps 2 through 4. If the sensor fails to zero twice contact Technical Assistance: 1-877-367-7891.
7. To return to Normal Mode press **Enter** and then press **Next** until "End" is displayed. Press **Enter** to return to Normal Mode.

Calibration

1. Remove the Philips screw on the front of the TX-12-ND. Pull the front cover of the unit off.
2. Assemble the 5 ppm gas cylinder and regulator together.
3. Check the pressure gauge on the regulator. If you have 25-psi or less you will need to replace the gas canister.
4. Place the test Hood from the regulator over the gas sensor.
5. Push **Next** 3 times to get to the CAL menu then push **Enter**. Press Next once to get to Span mode then press Enter, the display will flash back and forth between GAS and 5.0.
6. Start applying 5.0 ppm gas to the gas sensor by turning on the valve on the regulator.
Note: The sensor will look for the gas for 45 seconds. If no gas is applied or detected in that time, the display will return to CAL.
7. When the sensor detects the gas, the display will flash back and forth between the gas concentration and **SPn**, then the calibration will progress and the display will show the gas level for a maximum of 165 seconds.
8. When the calibration is successful, the display will flash back and forth between the gas concentration and **PAS**, then the display will show the calibration gas level and the calibration is done.

9. If the calibration fails, the display will flash back and forth between the gas concentration and **FAL** (fail). If this occurs, check the pressure gauge on the regulator. If the pressure is less than 25 psi the flow of gas may not be adequate to properly calibrate the unit. If there is proper pressure in the cylinder repeat steps 4 through 6. If the unit fails to calibrate twice contact Technical Assistance: 1-877-367-7891
10. Once the calibration has passed, remove gas and disassemble the cylinder and regulator.
11. Re-assemble the TX-12-ND (make sure the LED is aligned with the front case hole). Calibration is complete
12. See Calibration Flowchart on the inside of the housing.

MACURCO FIXED GAS DETECTION PRODUCTS LIMITED WARRANTY

Macurco warrants the TX-12-ND gas detector will be free from defective materials and workmanship for a period of two (2) years from date of manufacture (indicated on the inside cover of the TX-12-ND), provided it is maintained and used in accordance with Macurco instructions and/or recommendations. If any component becomes defective during the warranty period, it will be replaced or repaired free of charge, if the unit is returned in accordance with the instructions below. This warranty does not apply to units that have been altered or had repair attempted, or that have been subjected to abuse, accidental or otherwise. The above warranty is in lieu of all other express warranties, obligations or liabilities. THE IMPLIED WARRANTIES OF MERCHANTABILITY AND FITNESS FOR PARTICULAR PURPOSE ARE LIMITED TO A PERIOD OF TWO (2) YEARS FROM THE PURCHASE DATE. Macurco shall not be liable for any incidental or consequential damages for breach of this or any other warranty, express or implied, arising out of or related to the use of said gas detector. Manufacturer or its agent's liability shall be limited to replacement or repair as set forth above. Buyer's sole and exclusive remedies are return of the goods and repayment of the price, or repair and replacement of non-conforming goods or parts.

Manufactured by Aerionics, Inc.
Sioux Falls, SD
Email: info@aerionicsinc.com
Phone: 1-877-367-7891
Rev 08.19.2014
© Aerionics 2014. All rights reserved.
Macurco is a trademark of Aerionics, Inc.

